

AQ55L

The masters in linear EDM technology



HighSpeed EDM with up to 2g dynamic response

- Ceramic table
- Linear glass scales
- Linear motor for the X, Y, and Z axes
- Automatic fire extinguisher
- Cooling system
- SVC Circuit
- SQ Circuit super quality finish
- LAN interface

Technical Data

X / Y / Z axis travel (mm)	550 x 400 x 350
Table dimension (mm)	750 x 550
Worktank dims (mm)	950 x 725 x 410
Dielectric level (min - max, mm)	195 - 360
Max. workpiece weight (kg)	1,000
Max. electrode weight (kg)	50
Step resolution (mm)	0.0001
Max. positioning speed (mm/s)	5.0
Max. pulsation speed Z axis (m/min.)	36
Table - chuck distance (mm)	280 - 630
Controlled axes	4
Machine weight (kg)	6,000

C axis

Resolution (°)	0.001
Rotational speed(min. – max. rpm, continuous)	20 - 2000

Optional features

C axis (4 axes controlled)
C axis SE572 (4 axes controlled)
Electrode changer (4 - 50 positions)
RS232C interface
Uninterruptible power supply (UPS)
LAN facility
STP mode for carbide machining

CONTACT

Sodick Europe Ltd.
Rowley Drive, Baginton
Coventry, CV3 4LS
United Kingdom
Phone +44(0)2476214314
Fax +44(0)2476305680

Sodick Deutschland GmbH
Zentrale
Robert-Bosch-Str. 30
D - 71106 Magstadt
Phone +49 (0) 71 59 16 76 - 0
Fax +49 (0) 71 59 16 76 - 21

Sodick Contact
E-Mail: europa@sodick.eu.com
Internet: www.sodick.org

Sodick

AQ55L



The masters in linear EDM technology

HighSpeed EDM with up to 2g dynamic response

Side view

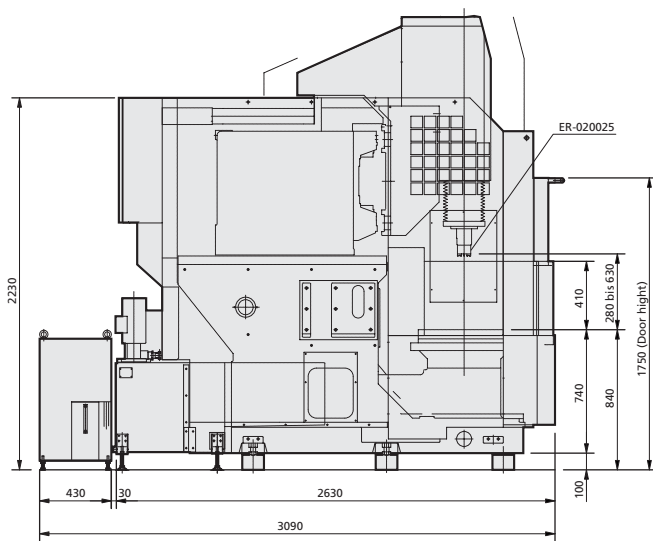

Front view

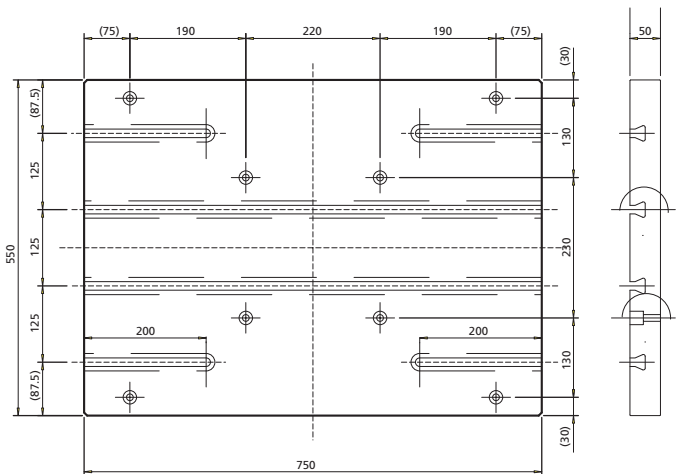
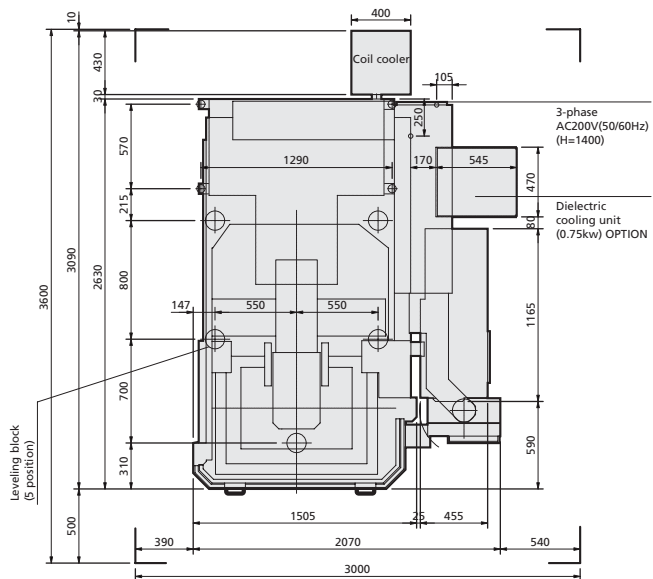
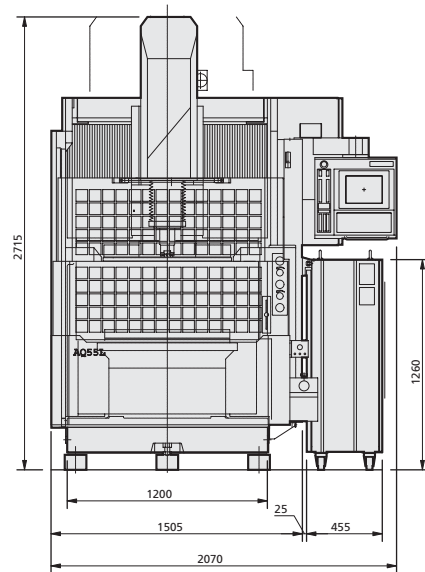

Top view

Working table

CONTACT

Sodick Europe Ltd.
Rowley Drive, Baginton
Coventry, CV3 4LS
United Kingdom
Phone +44(0)2476214314
Fax +44(0)2476305680

Sodick Deutschland GmbH
Zentrale
Robert-Bosch-Str. 30
D - 71106 Magstadt
Phone +49 (0) 71 59 16 76 - 0
Fax +49 (0) 71 59 16 76 - 21

Sodick Contact
E-Mail: europa@sodick.eu.com
Internet: www.sodick.org

Sodick