

AP450L



The masters in linear EDM technology

ultra-precision – high-tech for Greatest possible accuracy

- Linear motor for X, Y, U and V axes
- Linear glass scales for X, Y, U and V axes
- Ceramic components
- Automatic wire threader (AWT)
- Wire tension control
- Wire end remover
- Cooling system
- Voltage stabiliser
- Active Power Restart APR (UPS)
- Fine Measuring Control FMC
- SODICK Fine Corner Control SFCC
- Super PIKA OW
- 3D LQ Control LQ1W
- LAN interface

Technical Data

| | |
|------------------------------|-----------------|
| X / Y axis travel (mm) | 450 x 300 |
| U / V axis travel (mm) | 35 x 35 |
| Z axis travel (mm) | 150 |
| Max. workpiece dims (mm) | 600 x 400 x 130 |
| Max. workpiece weight (kg) | 100 |
| Controlled axes | 5 |
| Wire diameter (mm) | 0.05 - 0.3 |
| Wire tension (N) | 3 - 25 |
| Max. wire speed (mm/s) | 250 |
| Taper angle at 100 mm height | +/- 7° |

Optional features

LAN facility

CONTACT

Sodick Europe Ltd.
Rowley Drive, Baginton
Coventry, CV3 4LS
United Kingdom
Phone +44(0)2476214314
Fax +44(0)2476305680

Sodick Deutschland GmbH
Zentrale
Robert-Bosch-Str. 30
D - 71106 Magstadt
Phone +49 (0) 71 59 16 76 - 0
Fax +49 (0) 71 59 16 76 - 21

Sodick Contact
E-Mail: europe@sodick.eu.com
Internet: www.sodick.org

Sodick

AP450L



The masters in linear EDM technology

ultra-precision – high-tech for Greatest possible accuracy

Side view

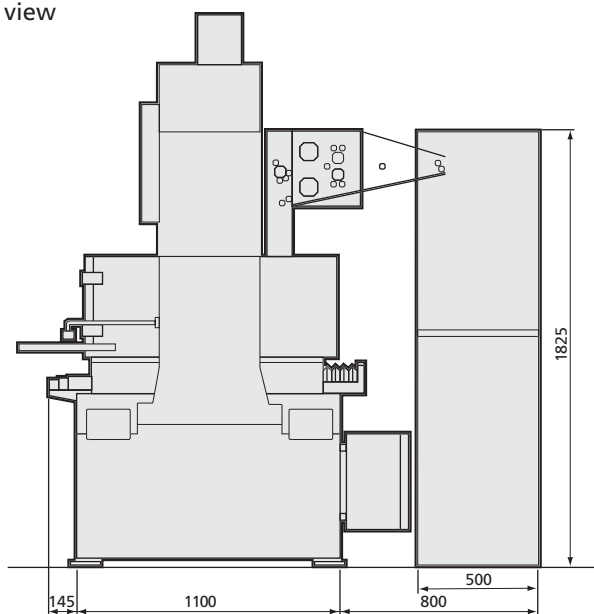

Front view

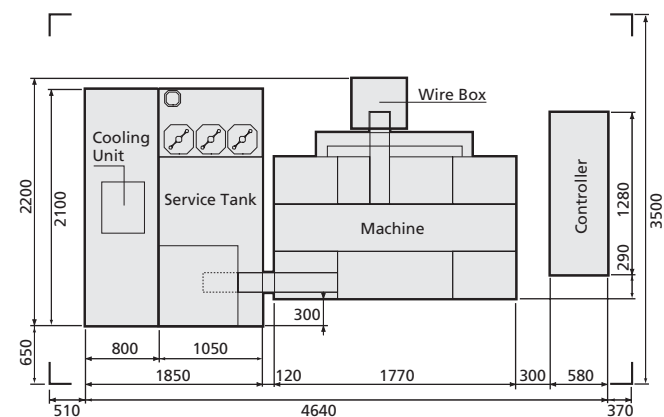
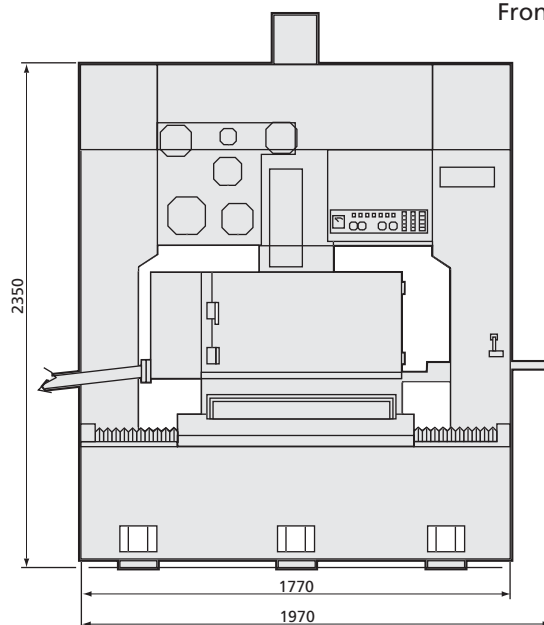

Top view

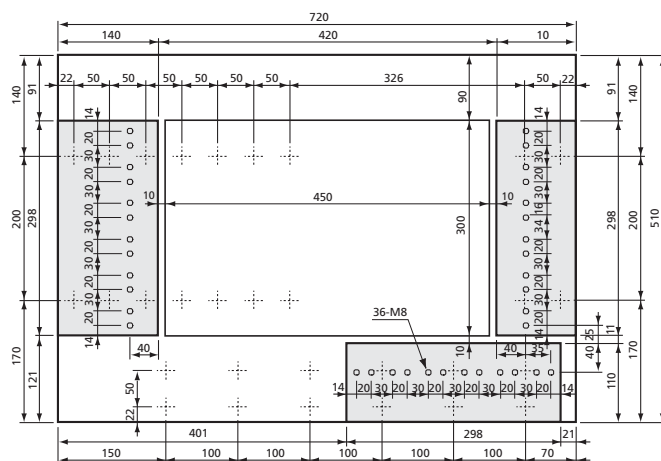

Working table

CONTACT

Sodick Europe Ltd.

Rowley Drive, Baginton
Coventry, CV3 4LS
United Kingdom
Phone +44(0)2476214314
Fax +44(0)2476305680

Sodick Deutschland GmbH

Zentrale
Robert-Bosch-Str. 30
D - 71106 Magstadt
Phone +49 (0) 71 59 16 76 - 0
Fax +49 (0) 71 59 16 76 - 21

Sodick Contact

E-Mail: europe@sodick.eu.com
Internet: www.sodick.org

Sodick